

USE 1/32" SHEET PACKING PIECE UNDER TAIL OF RIB 'R2' HERE DURING CONSTRUCTION

R2

USE DIHEDRAL GAUGE HERE

CABANE STRUT FIXING POINTS 1/20" SHEET BALSAs. ATTACH FLUSH WITH BOTTOM OF RIB

UPPER LEFT WING

INTERPLANE STRUT FIXING POINTS 1/20" SHEET BALSAs. ATTACH FLUSH WITH BOTTOM OF RIB

CUT TRAILING FROM 1/16" SHEET NOTCH FOR RIB SAND TO PROFILE BUILDING WING

DASHED LINES SHOW EXTRA RIBS REQUIRED FOR SCALE RIB SPACING

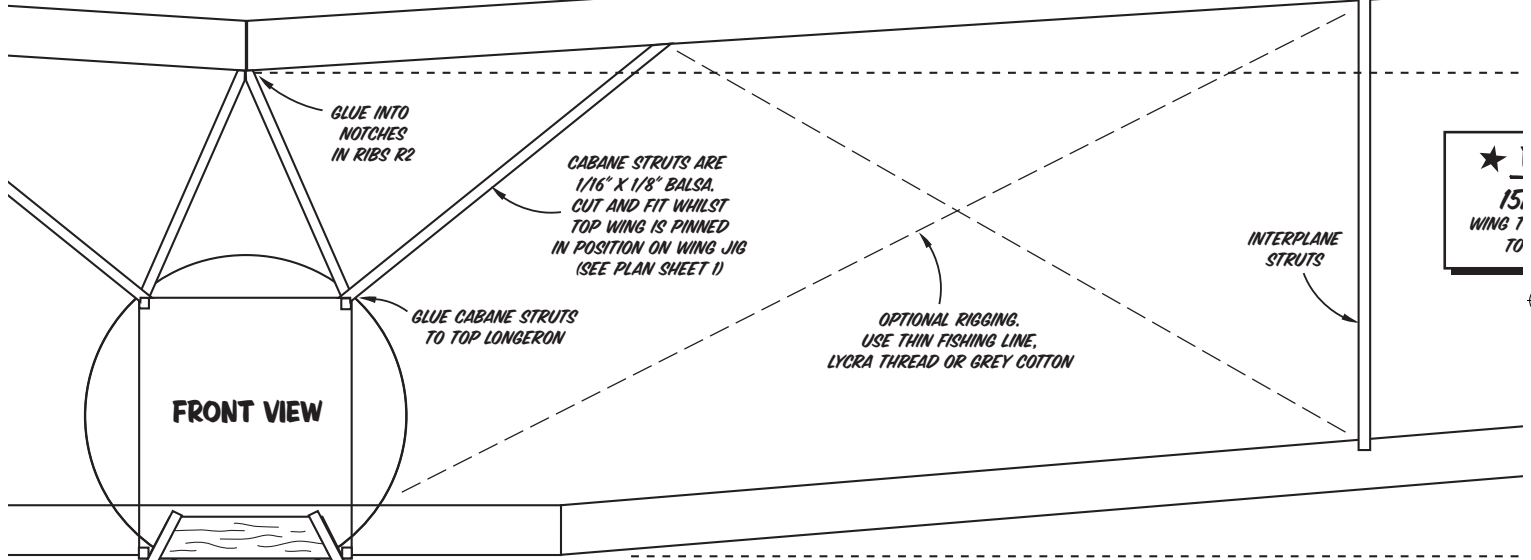
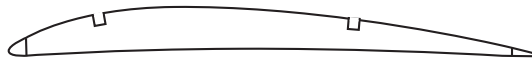
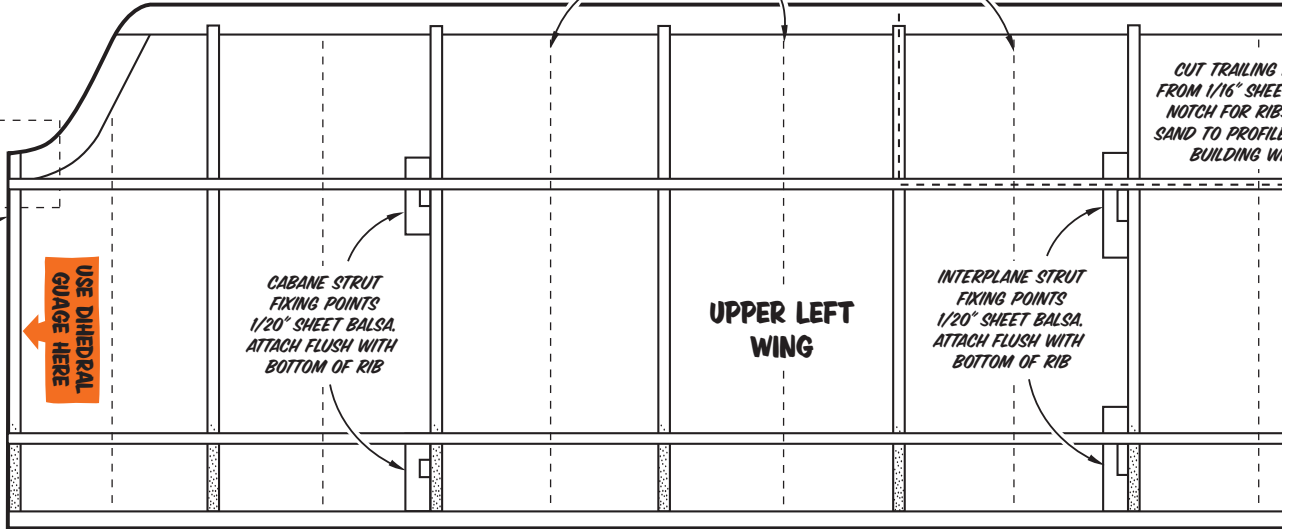

GLUE INTO NOTCHES IN RIBS R2

CABANE STRUTS ARE 1/16" X 1/8" BALSAs. CUT AND FIT WHILST TOP WING IS PINNED IN POSITION ON WING JIG (SEE PLAN SHEET 1)

GLUE CABANE STRUTS TO TOP LONGERON

OPTIONAL RIGGING. USE THIN FISHING LINE, LYCRA THREAD OR GREY COTTON

INTERPLANE STRUTS

★ 15, WING 1 TO

FRONT VIEW

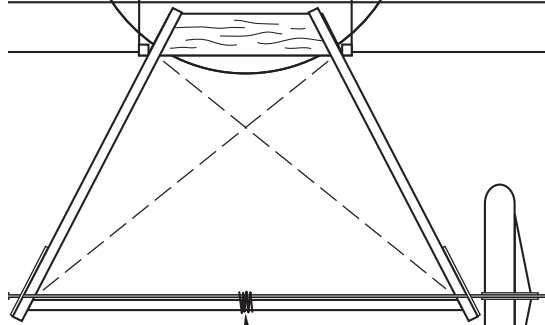

BIND AND GLUE WIRE AXLE TO THE SPREADER BAR AT CENTRE ONLY. THIS CREATES A SPRUNG UNDERCARRIAGE, SIMILAR TO THE FULL SIZE AIRCRAFT.

DIHEDRAL GAUGE

USE TO CANT ROOT RIBS

RIB R1 - 29 REQ.

RIB R2 - 2 REQ.

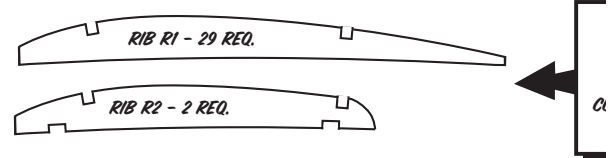

DID YOU KNOW?

THE 1/2 STRUTTER GOT IT'S NAME FROM IT'S UNUSUAL CABANE STRUT ARRANGEMENT (SEE FRONT VIEW ABOVE)

POSITION AND SIZE OF FRENCH ROUNDELS.

INTERPLANE STRUT FIXING POINTS 1/20" SHEET BALSAs. ATTACH FLUSH WITH TOP OF RIB

LOWER LEFT WING

CUT TRAILING EDGES FROM 1/16" SHEET BALSAs. NOTCH FOR RIBS, AND SAND TO PROFILE BEFORE BUILDING WINGS

